

NON-STANDARD TEMPLATE

COMPLETE FEET (NO LEG SEPARATOR)

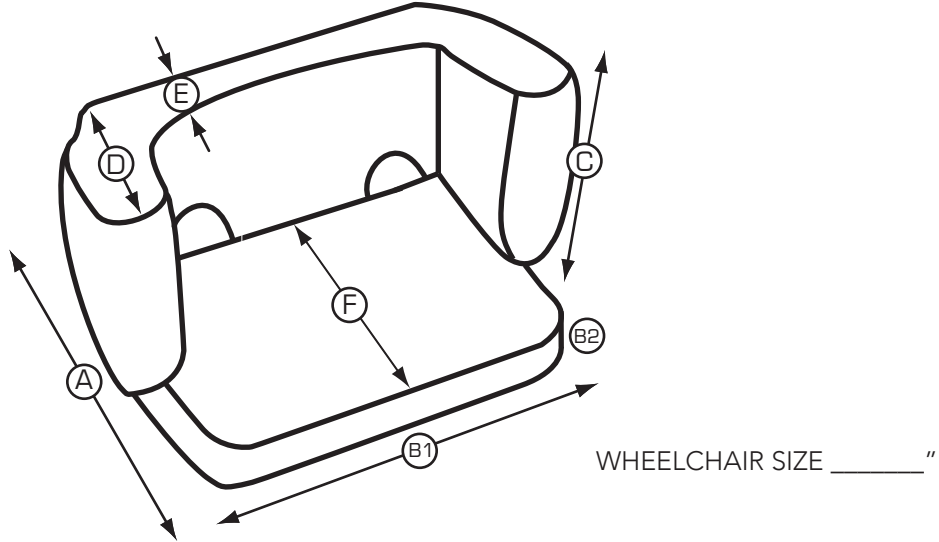

WHEELCHAIR SIZE _____"

PLEASE FILL OUT THE FOLLOWING

Product Information

- | | |
|--|--|
| 1) DIMENSION OF (A) : _____ " | 5) DIMENSION OF (D) : _____ " |
| 2) DIMENSION OF (B1) : _____ "
<small>Actual Width (Not Chair Size)</small> | 6) DIMENSION OF (E) : _____ " |
| 3) DIMENSION OF (B2) : _____ "
<small>Foot Support Thickness</small> | 7) INCLUDE GEL : Yes or No (circle one)*
<small>* Gel only available for foot support.</small> |
| 4) DIMENSION OF (C) : _____ " | 8) INSTRUCTIONS FOR (F) :
<small>* Draw a line in the middle of foot plate and align with the arrows.</small> |

Customer Information

CUSTOMER ACCT # : _____ SHIP TO LOCATION : _____
 CONTACT PERSON : _____
 PHONE # : _____
 _____ PATIENT REFERENCE : _____
 E-MAIL : _____ QUOTE REQUEST SUPPLY : _____

COMMENTS:

PLEASE FAX TO THE COMFORT COMPANY • 406.522.8563